

mounting direction

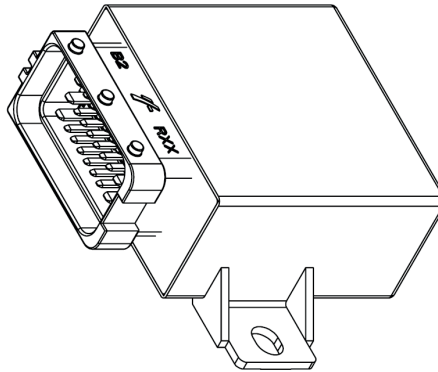

view of plug

DESCRIPTION

The CC16WP belongs to our 32-bit CAN I/O generation. 8 current-controlled PWM outputs enable, among other things, a switchable pull-up resistor (10 kΩ) and a switchable current sink (330 Ohm). The compact CAN controller has 1 CAN interface, optionally also CAN FD capable. The 2nd interface can be used as LIN, 2nd CAN or RS232 interface.

TECHNICAL DATA

Housing	Waterproof, sealed plastic housing
Connector	Delphi / Aptiv - 211PC249S0033
Weight	173 g
Temperature range (ISO 16750-4 compliant)	-40 °C to +85 °C
Environmental Protection	6K6 in the correct installation position (plug down)
Current consumption	26 mA at 24 V 45 mA at 12 V
Over-current protection	1 A + Load
Total Inputs and outputs	16 (6 analog inputs, 8 I/O's, 1 digital input, depending on assembly options - 2nd CAN bus, LIN bus or 2 additional digital inputs)
Inputs	Configurable as: Analog input 0...16 V, switchable to 0...32 V Frequency input Current input (330 Ω against GND) 1 kΩ pull up against V _{Ref}
Outputs	Configurable as: Digital, positive switching PWM output
Operating voltage	9 to 32 V (Code B at 12 V, Code E at 24 V acc. to ISO 16750-2) only for sensor supply = 5 V, otherwise 12.2 V to 32 V
Starting voltage	9 V (see operating voltage)
Overvoltage protection	≥ 33 V
Quiescent current	25 μA at 12 V and 24 V
Reverse polarity protection	Yes
CAN interface	ISO 11898-2:2016 capable CAN bus transceiver
LIN interface/RS232	Depending on assembly options

REGULATORY APPROVALS AND TESTING

E1 approval	ECE R10 06 8747
Electrical tests	Acc. to ISO 16750 – 2 resp. -4: Short circuit protection (without: RS232 interface) Reverse polarity Interruption pin and connector Overvoltage at TMax-20 °C Storage Test at TMax and TMin Operation Test at TMax and TMin Starting profile (form. pulse 4 according to ISO 7637) Load Dump Test B at 24 V (R _L =4Ω) Acc. to ISO 7637 - 2: pulse 1, 2a, 2b, 3a, 3b Acc. to ISO 10605: ESD up to ± 15 kV Bulk current injection acc. to 11452-4: 3. Ed. 2005+ Corr.. 1 2009 up to 100 mA Free field (ISO 11452-2:2 ed. 2004) up ro 100 V/M

SOFTWARE/PROGRAMMING

Programming System	MRS APPLICS STUDIO The Applics Studio is the new development and tool platform for our assemblies. Program your MRS controls quickly and easily with our stand-alone software. The focus is on your application.
--------------------	--



INPUT FEATURES - SUMMARY

Pin A3, A4, A5, A6, B6, C4 Programmable as analog or digital input Resolution 12 Bit			Pin B1, B8, C1, C2, C3, C6, C7, C8 Programmable as analog or digital input Resolution 12 Bit		
Voltage input 0...16 V (see A) ¹	Input resistance	40 kΩ	Voltage input 0...32 V (see E) ¹	Input resistance	30 kΩ
	Input frequency	$f_g^2 = 170 \text{ Hz}$		Input frequency	$f_g^2 = 280 \text{ Hz}$
	Accuracy	$\leq 3 \%$		Accuracy	$\leq 3 \%$
Voltage input 0...32 V (see B)	Input resistance	36 kΩ	Pin B3 Programmable as analog or digital input		
	Input frequency	$f_g = 340 \text{ Hz}$	Resolution	12 Bit	
	Accuracy	$\leq 3 \%$	Voltage input 0...16 V (see A) ¹		
Frequency input (see D) ³	Input resistance	40 kΩ	Input resistance	34 kΩ	
	Input frequency	5.3 V	Input frequency	$f_g^2 = 160 \text{ Hz}$	
	Turn-on threshold	50 μs	Accuracy	$\leq 3 \%$	
	Accuracy	$\geq 8 \text{ Hz and } \leq 10 \text{ kHz max. } \pm 3 \%$	¹ standard configuration ² Cutoff frequency (-3 dB), measured with 0-10 V _{Peak} ³ when standard configuration is used		
Current input 0...24.5 mA (see C)	Input resistance	330 Ω against GND	Sensor input (see E)		
Sensor input (see E)	Input resistance	1 kΩ against A7 (sensor supply)	Pin A2, B2 (depending on assembly options) Programmable as digital input Resolution 12 Bit		
Digital input Positive (see G)	Input resistance	22.7 kΩ	Input resistance		
	Turn-on threshold	6 V	Turn-on threshold		
	Turn-off threshold	4.8 V	Turn-off threshold		
	Min. pulse width	$\geq 20 \text{ ms measured at } 500 \text{ kbaud}$	Min. pulse width		



OUTPUT FEATURES - SUMMARY

Pin B1, B8, C1, C2, C3, C6, C7, C8	Protective circuit for inductive loads	Integrated
	Wire fault diagnostics	Possible via current sense
	Short circuit diagnostics	Possible via current sense
Digital, positive switching (high side; see E) including INA current sense	Switching voltage Switching current Accuracy INA293 current sense(for measuring ≤ 100 mA use the calibrated current value with function: <code>calibr_get_value()</code>)	9-32 V DC see table 1 Digit ≈ 1 mA for 100 mA $\geq 3\% \geq 1$ A
PWM output (see E)	Output frequency Resolution Switching current	10 Hz - 1 kHz 1 % see table
Short circuit resistance against GND and US	Switching-off is controlled by high side driver for each output channel	

PWM channels

Frequency 0 (Timer Channel 0)

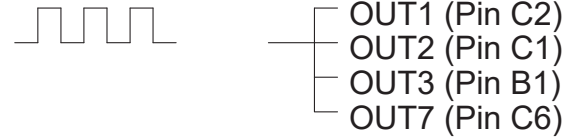

Frequency 1 (Timer Channel 1)

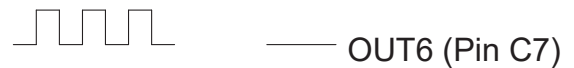

Frequency 2 (Timer Channel 2)

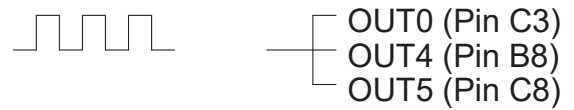

Duty Cycle selectable different per output

PERFORMANCE TEST T_{+85 °C} HSD-OUTPUTS

Test without PWM	Test No.	Load	Duration	Test with PWM	Test No.	PWM / DC	Load	Duration
	1	2.5 A / output (Σ 20 A)	Permanent		1	100 Hz 50 %	2.5 A / output (Σ 20 A)	Permanent
	2	3 A / Output (Σ 24 A)	max. 4 h		2	200 Hz 50 %	2.5 A / output (Σ 20 A)	Permanent
					3	300 Hz 90 %	2.5 A / output (Σ 20 A)	Permanent
					4	400 Hz 50 %	2.5 A / output (Σ 20 A)	Permanent
					5	1 kHz 50 %	2.5 A / output (Σ 20 A)	max. 5 Min

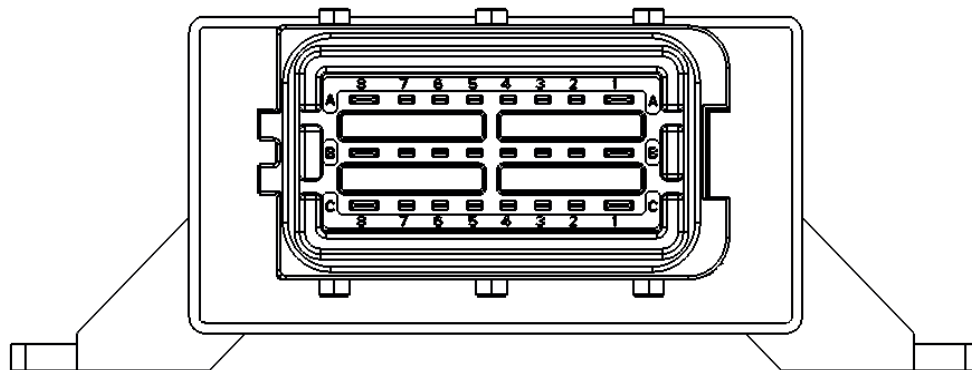



PIN ASSIGNMENT POWER SUPPLY AND INTERFACES

Pin	Description	Pin	Description
A1	Operating voltage for outputs B1, C1-C3, processor ⁴	B2	CAN1 - L oder Digital input (depending on assembly options)
A2	LIN master / CAN1 - H or digital input (depending on assembly options)	B3	ID pin or analog input (acc. to p.2)
A7	Sensor supply, switchable to 5 V (DO_VREF_EN), 8.5 V (DCDC_8V5) or 10 V (DCDC_10V), 500 mA max	B4	CAN0 - H
A8	Operating voltage for outputs B8, C6-C8, processor ⁴	B5	Contact 15 / ignition
		B7	Ground
		C5	CAN0 - L

PIN ASSIGNMENT INPUTS AND OUTPUTS

Pin	Signal	Description	Pin	Signal	Description
A2	DI_INTERFACES_A	Digital input (depending on assembly options)	B8	AI_OUT4 PWM_HSD2_OUT4 DO_HSD2_OUT4 AI_INA_OUT4	Analog input 4 or PWM output ⁵ 4 or Digital output 4 and INA current sense
A3	AI_A_IN5 FREQ_A_IN5 DO_RS5 PU_A_IN5 PD_A_IN5	Analog input 5 0-16 V or frequency input 5 Input configurable as: Range switching 0-32 V 1 kΩ pull up 330 Ω pull down	C1	AI_OUT2 PWM_HSD1_OUT2 DO_HSD1_OUT2 AI_INA_OUT2	Analog input 2 or PWM output ⁵ 2 or Digital output 2 and INA current sense
A4	AI_A_IN4 FREQ_A_IN4 DO_RS4 PU_A_IN4 PD_A_IN4	Analog input 4 0-16 V or Frequency input 4 Input configurable as: Range switching 0-32 V 1 kΩ pull up 330 Ω pull down	C2	AI_OUT1 PWM_HSD1_OUT1 DO_HSD1_OUT1 AI_INA_OUT1	Analog input 1 or PWM output ⁵ 1 or Digital output 1 and INA current sense
A5	AI_A_IN2 FREQ_A_IN2 DO_RS2 PU_A_IN2 PD_A_IN2	Analog input 2 0-16 V or Frequency input 2 Input configurable as: Range switching 0-32 V 1 kΩ pull up 330 Ω pull down	C3	AI_OUT0 PWM_HSD1_OUT0 DO_HSD1_OUT0 AI_INA_OUT0	Analog input 0 or PWM output ⁵ 0 or Digital output 0 and INA current sense
A6	AI_A_IN1 FREQ_A_IN1 DO_RS1 PU_A_IN1 PD_A_IN1	Analog input 1 0-16 V or Frequency input 1 Input configurable as: Range switching 0-32 V 1 kΩ pull up 330 Ω pull down	C4	AI_A_IN3 FREQ_A_IN3 DO_RS3 PU_A_IN3 PD_A_IN3	Analog input 0 0-16 V or Frequency input 0 Input configurable as: Range switching 0-32 V 1 kΩ pull up 330 Ω pull down
B1	AI_OUT3 PWM_HSD1_OUT3 DO_HSD1_OUT3 AI_INA_OUT3	Analog input 3 or PWM output 3 ⁵ Digital output 3 or and INA current sense	C6	AI_OUT7 PWM_HSD2_OUT7 DO_HSD2_OUT7 AI_INA_OUT7	Analog input 7 or PWM output ⁵ 7 or Digital output 7 and INA current sense
B2	DI_INTERFACES_B	Digital input (depending on assembly options)	C7	AI_OUT6 PWM_HSD2_OUT6 DO_HSD2_OUT6 AI_INA_OUT6	Analog input 6 or PWM output ⁵ 6 or Digital output 6 and INA current sense
B3	AI_ID	Analog input 0-16 V or ident pin	C8	AI_OUT5 PWM_HSD2_OUT5 DO_HSD2_OUT5 AI_INA_OUT5	Analog input 5 or PWM output ⁵ 5 or Digital output 5 and INA current sense
B6	AI_A_IN0 FREQ_A_IN0 DO_RS0 PU_A_IN0 PD_A_IN0	Analog input 0 0-16 V or Frequency input 0 Input configurable as: Range switching 0-32 V 1 kΩ pull up 330 Ω pull down			

⁴min. switch-off time = 2.5 s

⁵ initial value with f = 1 kHz and 0% DC, DC switchable in 1% steps (1000=100%)



PIN FEATURE MAP

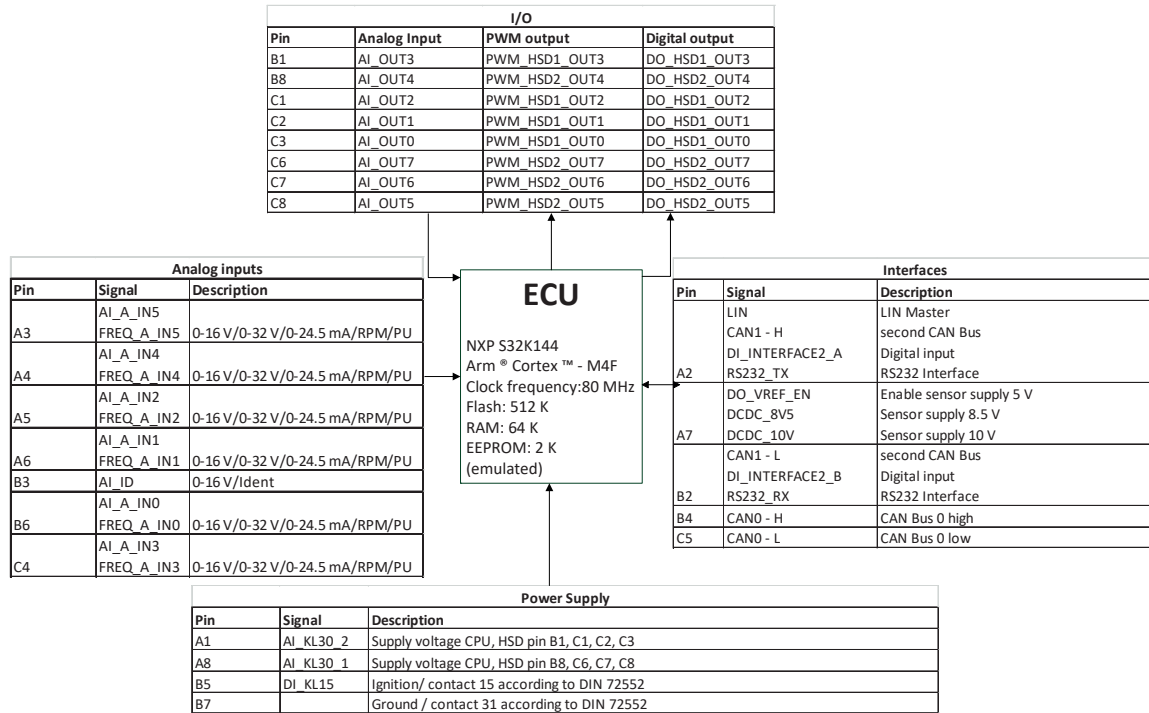

BLOCK FUNCTION DIAGRAM

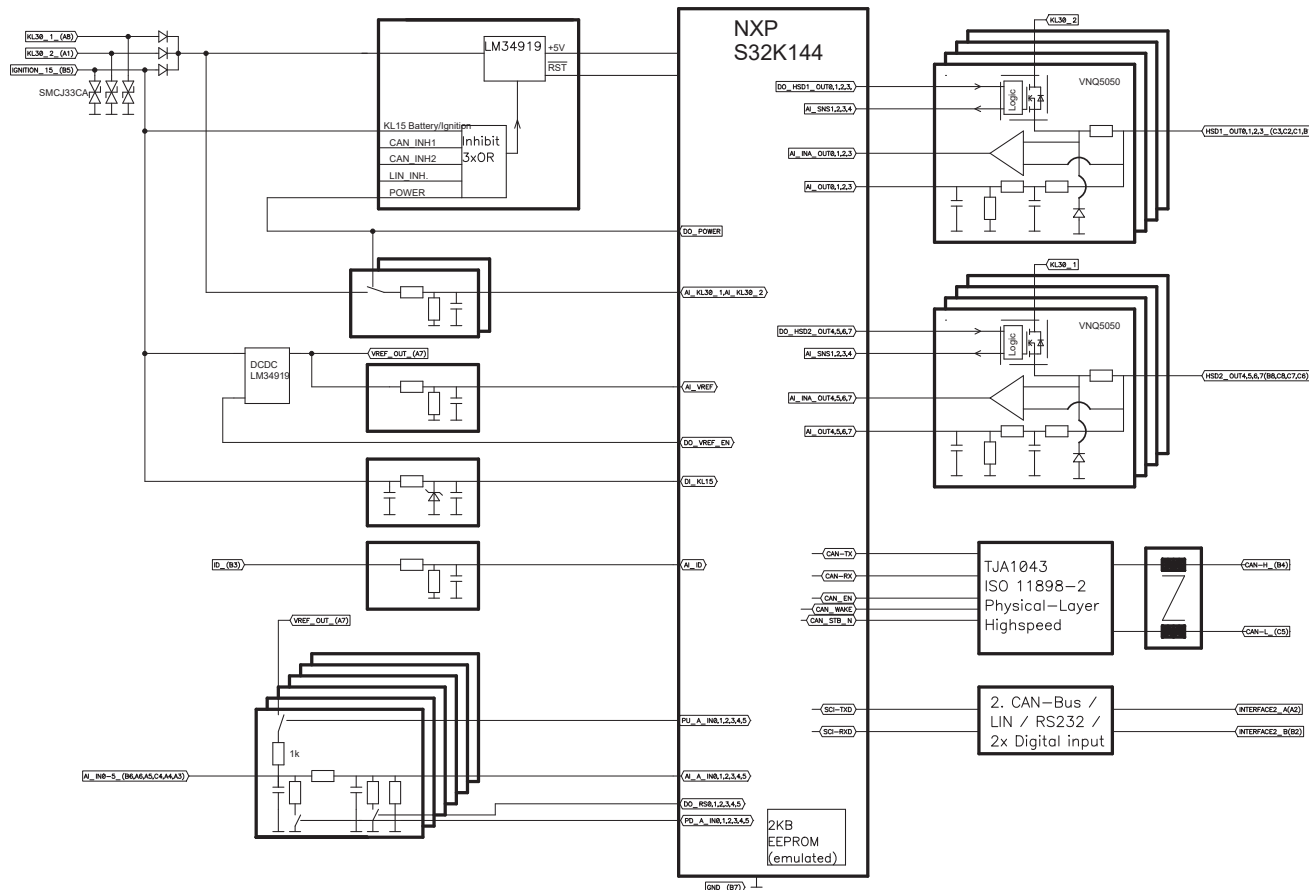

TECHNICAL DRAWING IN MM [INCH]

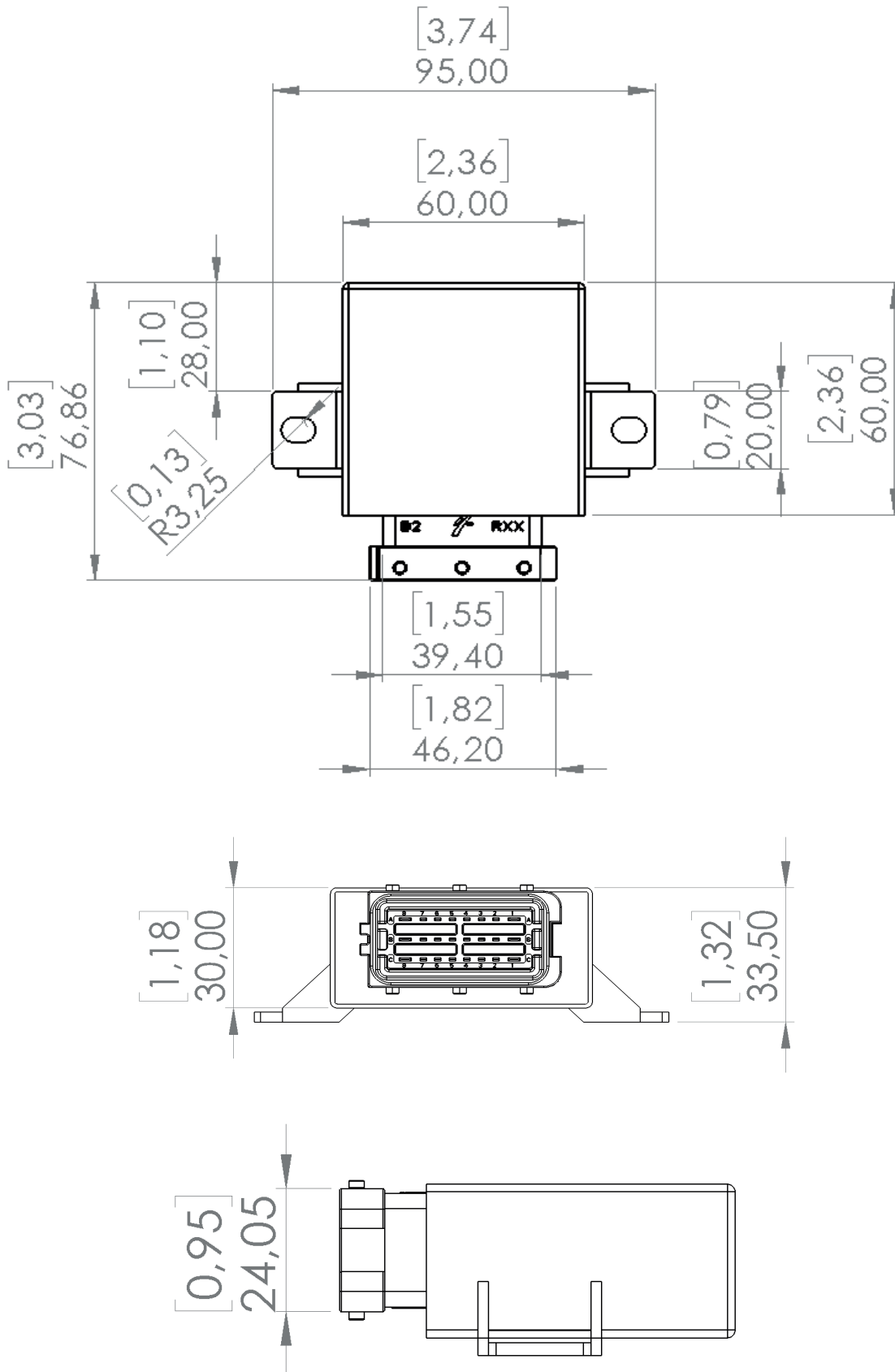



ASSEMBLY OPTIONS AND ORDER INFORMATION

	Inputs					Outputs	Serial Interface		Wake up source	Remarks
	A Voltage 0 – 16 V	B Voltage 0 – 30 V	C Current 0 - 24.5 mA	D Frequency Hz	E PT1000 1 kΩ pull up on sensor supply		F I/O's (can be used as analog or digital inputs with PWM)	CAN Bus high speed		
1.154.211.00	A3, A4, A5, A6, B3, B6, C4	A3, A4, A5, A6, B6, C4	A3, A4, A5, A6, B6, C4	A3, A4, A5, A6, B6, C4	A3, A4, A5, A6, B6, C4	B1, B8, C1, C2, C3, C6, C7, C8	B4, C5	A2	CAN, LIN, KL15, DO_ POWER	With 12 V LIN Bus (at 24 V power supply), sonsor supply only 12 V Aktivation of LIN via VREF (DO_VREF_EN and DCDC_10V)
1.154.300.00	A3, A4, A5, A6, B3, B6, C4	A3, A4, A5, A6, B6, C4	A3, A4, A5, A6, B6, C4	A3, A4, A5, A6, B6, C4	A3, A4, A5, A6, B6, C4	B1, B8, C1, C2, C3, C6, C7, C8	A2, B2, B4, C5		CAN, KL15, DO_POW- ER	
1.154.300.10	A3, A4, A5, A6, B3, B6, C4	A3, A4, A5, A6, B6, C4	A3, A4, A5, A6, B6, C4	A3, A4, A5, A6, B6, C4	A3, A4, A5, A6, B6, C4	B1, B8, C1, C2, C3, C6, C7, C8	A2, B2 B4, C5		-	Switching on - only contact 15 (B5), no wake up
1.154.310.00	A3, A4, A5, A6, B3, B6, C4	A3, A4, A5, A6, B6, C4	A3, A4, A5, A6, B6, C4	A3, A4, A5, A6, B6, C4	A3, A4, A5, A6, B6, C4	B1, B8, C1, C2, C3, C6, C7, C8	B4, C5	A2	CAN, LIN, KL15, DO_ POWER	Aktivation of LIN via VREF (DO_VREF_EN and DCDC_10V)
1.154.320.00	A3, A4, A5, A6, B3, B6, C4	A3, A4, A5, A6, B6, C4	A3, A4, A5, A6, B6, C4	A3, A4, A5, A6, B6, C4	A3, A4, A5, A6, B6, C4	B1, B8, C1, C2, C3, C6, C7, C8	B4, C5		CAN, KL15, DO_POW- ER	RS232 at A2 and B2
1.154.330.00	A3, A4, A5, A6, B3, B6, C4	A3, A4, A5, A6, B6, C4	A3, A4, A5, A6, B6, C4	A3, A4, A5, A6, B6, C4	A3, A4, A5, A6, B6, C4	B1, B8, C1, C2, C3, C6, C7, C8	B4, C5		CAN, KL15, DO_POW- ER	Digital inputs at A2 and B2
1.154.302.00	A3, A4, A5, A6, B3, B6, C4	A3, A4, A5, A6, B6, C4	A3, A4, A5, A6, B6, C4	A3, A4, A5, A6, B6, C4	A3, A4, A5, A6, B6, C4	B1, B8, C1, C2, C3, C6, C7, C8	A2, B2, B4, C5		CAN, KL15, DO_POW- ER	2X CAN Bus, 2MB, AEF certified



ACCESSORIES

Description	Order number
Applics Studio Bundle	1.100.200.00
Cable set CC16WP for programming	110490
Connector package CC16WP	110421
PCAN-USB interface	105358



On request also available with matching DEUTSCH DT plug

Your advantages:

- High reliability and robust quality
- Use in extreme temperatures and high humidity

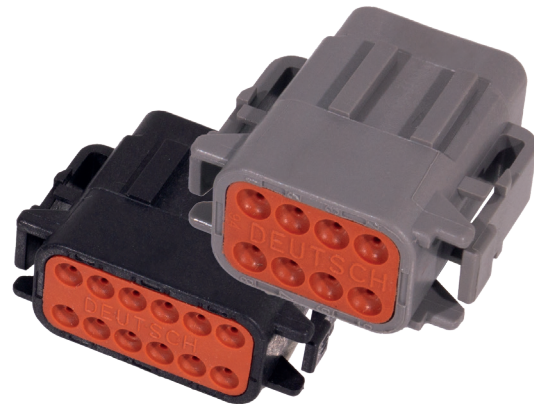

MANUFACTURER

MRS Electronic GmbH & Co. KG
Klaus-Gutsch-Str. 7
78628 Rottweil

NOTES ON WIRING AND CABLE ROUTING

The electronic system and the power outputs of a control unit must be supplied by the same power supply system.

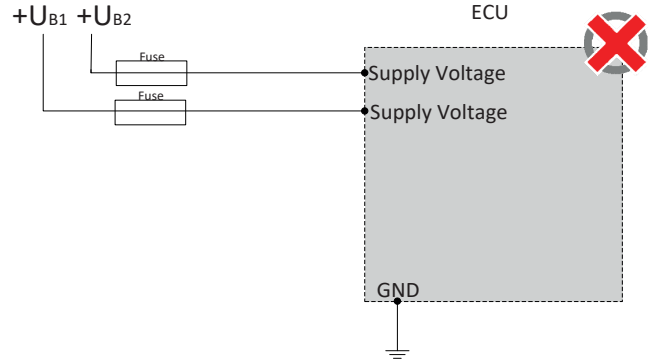
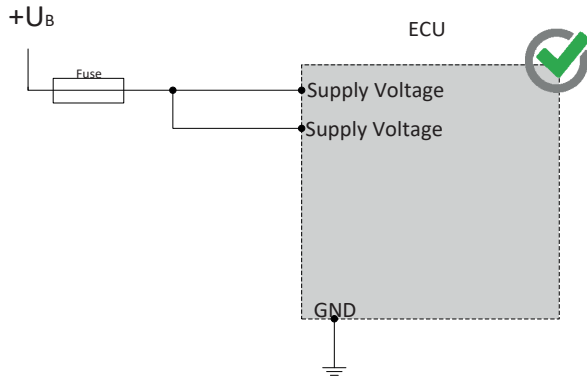

PWM outputs may not be connected with each other or bypassed.

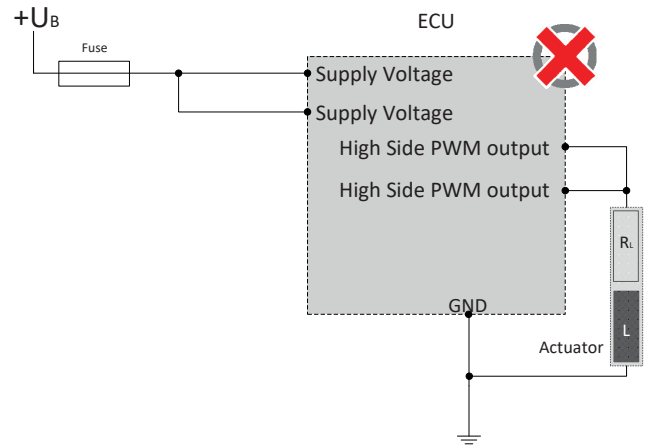
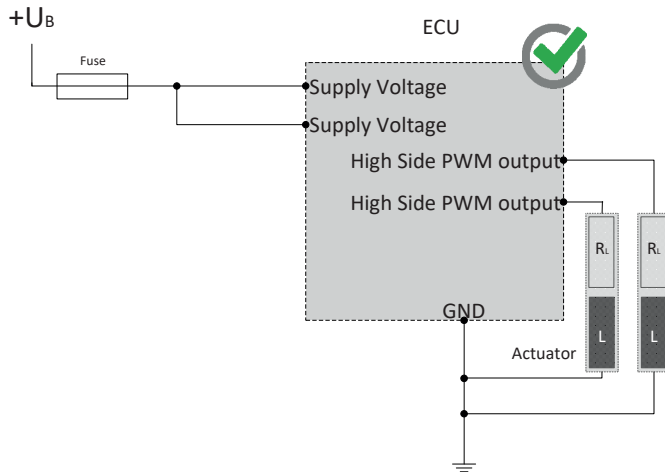

The pins (I/Os) can be used in combination and may not be switched externally against a higher voltage level than supply voltage.

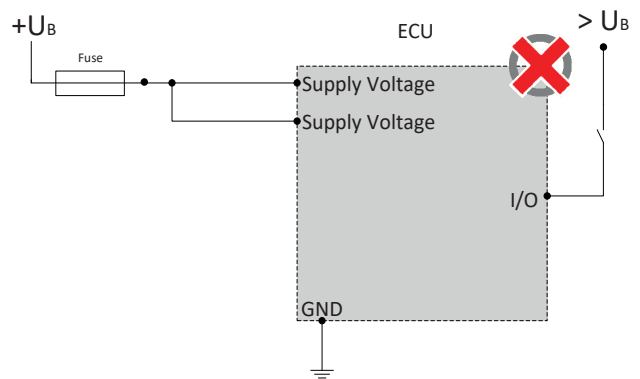
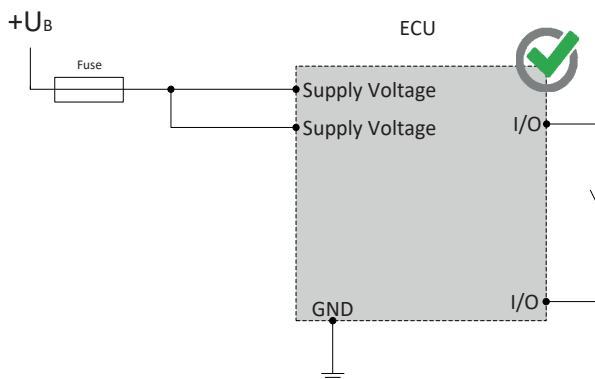

NOTES ON WIRING AND CABLE ROUTING

Hightside outputs may only be switched to ground.

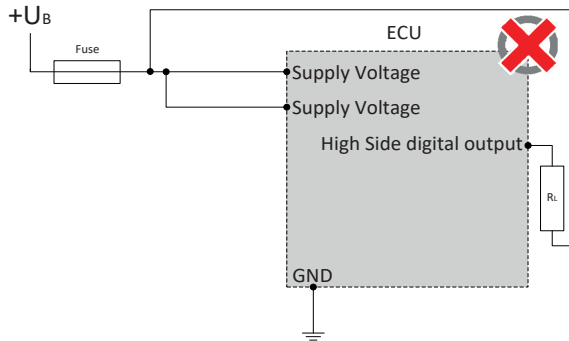
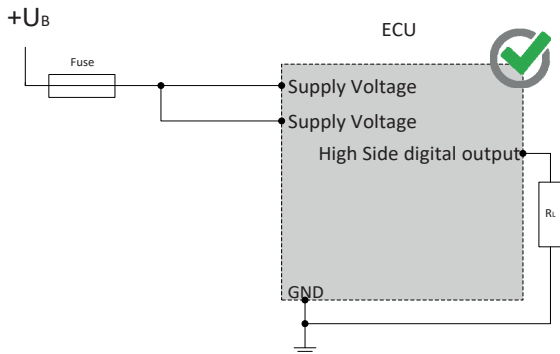
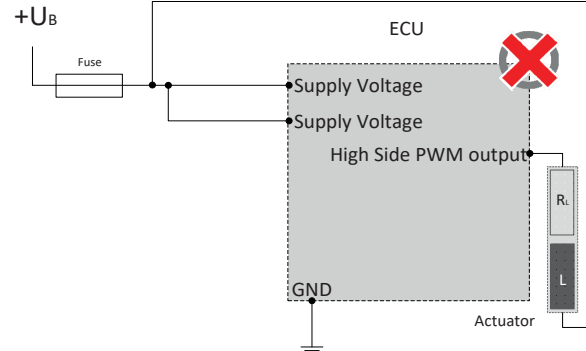
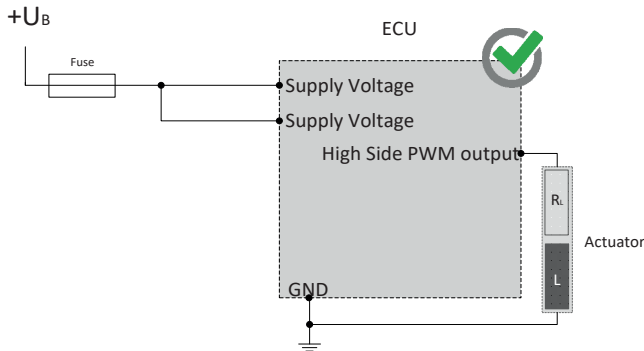

The sensor supplies can be "lifted" through an external circuitry, for example the creation of higher voltage, as they only work as a voltage source but not as voltage drain. The lift of a voltage source may lead to unforeseen malfunctions and damages of the control unit in case of permanent operation.

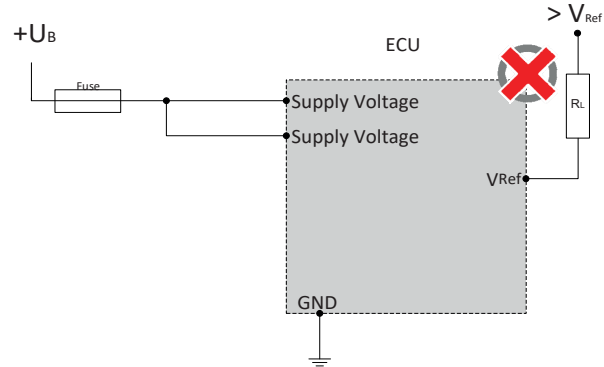
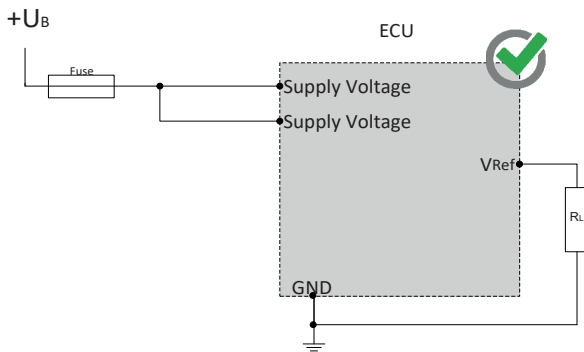

CAN bus communication is the main communication between the control unit and the vehicle. Therefore, connect the CAN bus with special care and check the correct communication with the vehicle to avoid undesired behavior.

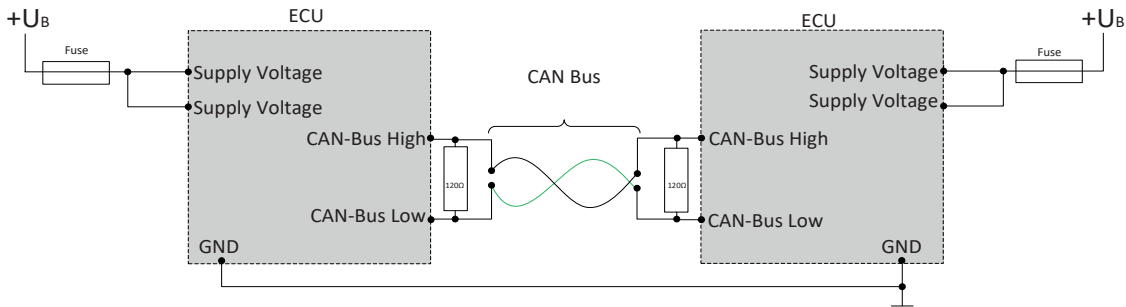



NOTES ON WIRING AND CABLE ROUTING

When using the input with pull-down resistance (using DOM_PD), you must not connect a greater voltage than 9 V to the input.

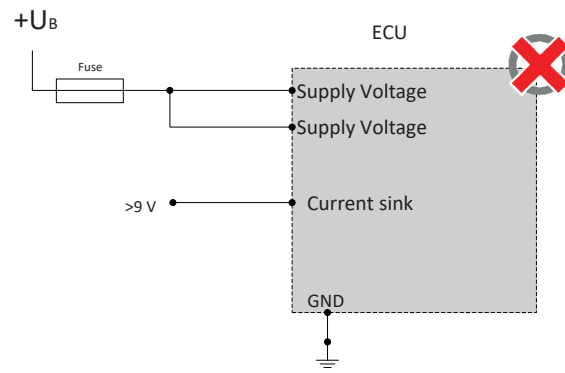
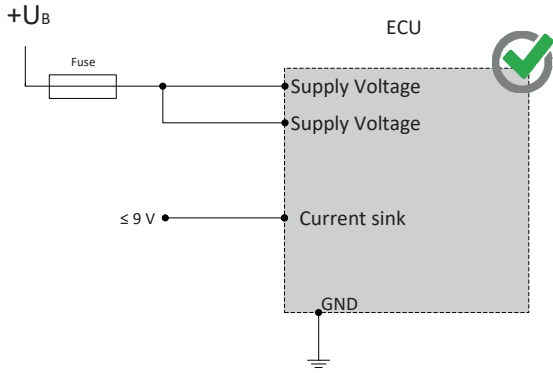

SAFETY AND INSTALLATION INFORMATION

It is essential to read the instructions in full thoroughly before working with the device.

Please note and comply with the instructions in the operating instructions and the information in the device data sheet, see www.mrs-electronic.de

Staff qualification: Only staff with the appropriate qualifications may work on this device or in its proximity.

SAFETY



WARNING! Danger as a result of a malfunction of the entire system.

Unforeseen reactions or malfunctions of the entire system may jeopardise the safety of people or the machine.

- Ensure that the device is equipped with the correct software and that the wiring and settings on the hardware are appropriate.



WARNING! Danger as a result of unprotected moving components.

Unforeseen dangers may occur from the entire system when putting the device into operation and maintaining it.

- Switch the entire system off before carrying out any work and prevent it from unintentionally switching back on.
- Before putting the device into operation, ensure that the entire system and parts of the system are safe.
- The device should never be connected or separated under load or voltage.



CAUTION! Risk of burns from the housing.

The temperature of the device housing may be elevated.

- Do not touch the housing and let all system components cool before working on the system.

PROPER USE

The device is used to control or switch one or more electrical systems or sub-systems in motor vehicles and machines and may only be used for this purpose. The device may only be used in an industrial setting.



WARNING! Danger caused by incorrect use.

The device is only intended for use in motor vehicles and machines.

- Use in safety-related system parts for personal protection is not permitted.
- Do not use the device in areas where there is a risk of explosion.

Correct use:

- operating the device within the operating areas specified and approved in the associated data sheet.
- strict compliance with these instructions and no other actions which may jeopardise the safety of individuals or the functionality of the device.

Obligations of the manufacturer of entire systems

It is necessary to ensure that only functional devices are used. If devices fail or malfunction, they must be replaced immediately.

System developments, installation and the putting into operation of electrical systems may only be carried out by trained and experienced staff who are sufficiently familiar with the handling of the components used and the entire system.

It is necessary to ensure that the wiring and programming of the device does not lead to safety-related malfunctions of the entire system in the event of a failure or a malfunction. System behaviour of this type can lead to a danger to life or high levels of material damage.

The manufacturer of the entire system is responsible for the correct connection of the entire periphery (e.g. cable cross sections, correct selection/connection of sensors/actuators).

Opening the device, making changes to the device and carrying out repairs are all prohibited. Changes or repairs made to the cabling can lead to dangerous malfunctions. Repairs may only be carried out by MRS.

Installation

The installation location must be selected so the device is exposed to as low a mechanical and thermal load as possible. The device may not be exposed to any chemical loads.

Install the device in such a manner that the plugs point downwards. This means condensation can flow off the device. Single seals on the cables/leads must be used to ensure that no water gets into the device.

Putting into operation

The device may only be put into operation by qualified staff. This may only occur when the status of the entire system corresponds to the applicable guidelines and regulations.

FAULT CORRECTION AND MAINTENANCE



NOTE The device is maintenance-free and may not be opened.

- If the device has damage to the housing, latches, seals or flat plugs, it must be taken out of operation.

Fault correction and cleaning work may only be carried out with the power turned off. Remove the device to correct faults and to clean it.

Check the integrity of the housing and all flat plugs, connections and pins for mechanical damage, damage caused by overheating, insulation damage and corrosion. In the event of faulty switching, check the software, switches and settings.

Do not clean the device with high pressure cleaners or steam jets. Do not use aggressive solvents or abrasive substances.